

DUR-A-LIFT®

DLT2 SERIES

TELESCOPIC ARTICULATING
MATERIAL HANDLING OR PERSONNEL

REACH UP TO 67 FEET!



DLT2-60DU PICTURED

SPECIFICATIONS

DLT2-60

WORKING HEIGHT*	67'
SIDE REACH	39'2"
APPROX. STOWED TRAVEL HEIGHT	12'
HEIGHT TO BOTTOM OF PLATFORM*	62'
BASKET CAPACITY (MH, DU)	400#
BASKET CAPACITY NOT USING JIB (DU)	550#
BASKET CAPACITY (DP)	600#
APPROX. LIFT WEIGHT	5950#
ARTICULATING ARM TRAVEL	0° to 91°
MAIN BOOM TRAVEL	-26° to 75°
EXTENSION TRAVEL	134"

Dur-A-Lift Inc. reserves the right to improve models and change specifications without notice or obligation. Dur-A-Lift equipment meets or exceeds all applicable ANSI Standards as of the date of manufacture.

*Maximum height achievable with addition of the optional 22" basket elevator.

WORKING HEIGHT UP TO 67'; SIDE REACH TO 39'2"

MATERIAL HANDLING OR DOUBLE-PERSON

180-DEGREE BASKET ROTATOR

BASKET ELEVATOR OPTION

TOP-MOUNTED JIB LIFTS UP TO 1000#

INSULATED (DLT2); NON-INSULATED (DLT2S)

TOP-MOUNTED JIB & WINCH

The optional top-mounted jib and winch (DU, MH baskets) allows the operator to rotate the jib to work on either side of the rotating basket.



WE SPEAK BUCKET TRUCK

DUR-A-LIFT.COM/GUIDE

BROWSE ALL MODEL OPTIONS ONLINE!



DLT2 SERIES

STANDARD

Proportional controls; lower override controls; engine start/stop from basket; basket access from ground; compensated upper boom; hydraulic basket leveling; continuous rotation; joystick and lockout controls; 180° basket rotator

OPTIONAL

High electrical resistant controls; outriggers; basket liner for fiberglass baskets; fiberglass main and articulating booms; tool circuits; D.C. backup system; 22" basket elevator; aluminum basket; non-insulated version available (DLT2S); 110 v outlet at basket (DLT2S)

INSULATED/NON-INSULATED

DLT2-60: insulated (Category C or D)

DLT2S-60: non-insulated

REACH DIAGRAM

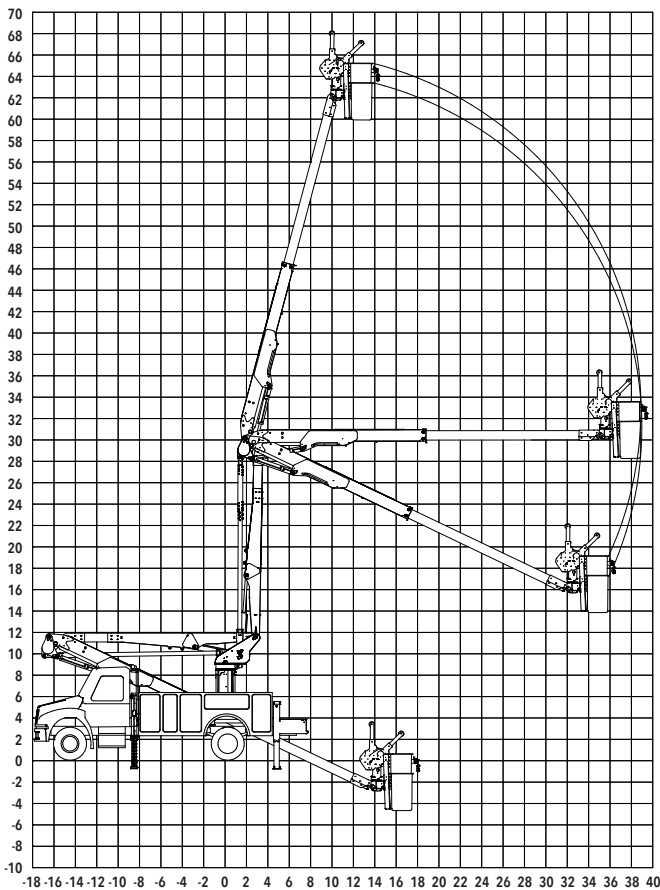

CHASSIS REQUIREMENT, MIN.: 26,000 GVWR
CHASSIS CAB TO AXLE REQUIREMENT, MIN.: 110"



MH BASKET



DU BASKET



DP BASKET

BASKETS

MH BASKET: Single-person, material handling; top-mounted jib and winch lifts up to 1000#; upper and lower winch control; 400# basket capacity; 24" X 30" fiberglass or aluminum basket

DP BASKET: Double-person, personnel; 600# basket capacity; 24" X 42" fiberglass or aluminum basket

DU BASKET: Dual configuration; double-person, personnel or single-person, material handling; top-mounted jib and winch lifts up to 1000#; 550# basket capacity when not using winch; 400# basket capacity when using winch; 24" X 42" fiberglass or aluminum basket



Baskets available in aluminum or fiberglass formats.



DLT2-60DU PICTURED



READ MORE

BASKET ELEVATOR - The hydraulically activated basket elevator (optional) allows the operator to raise the basket without repositioning the booms or the jib.



DUR-A-LIFT, INC., 2002 KINGBIRD AVENUE, PO BOX 31, GEORGE, IOWA 51237
1-877-438-7254 | SALES@DUR-A-LIFT.COM | DUR-A-LIFT.COM