



DVS-29

TELESCOPIC AERIAL LIFT VAN
SPLICING LAB & WALK-IN BASKET OPTIONS
EXTERIOR & INTERIOR STORAGE OPTIONS!



DVS-29 AERIAL LIFT VAN

SPECIFICATIONS

	DVS-29
WORKING HEIGHT	34'
SIDE REACH	21'
APPROX. STOWED TRAVEL HEIGHT	10'1"
HEIGHT TO BOTTOM OF PLATFORM	29'
BASKET CAPACITY	350#
APPROX. LIFT WEIGHT	2000#
BOOM TRAVEL	-5° to 80°
EXTENSION TRAVEL	108"

Dur-A-Lift Inc. reserves the right to improve models and change specifications without notice or obligation. Dur-A-Lift equipment meets or exceeds all applicable ANSI Standards as of the date of manufacture.

NON-INSULATED, TELESCOPIC BUCKET VAN
WORKING HEIGHT UP TO 34'; SIDE REACH TO 21'
SINGLE-PERSON FIBERGLASS BASKET
SPLICING LAB AND WALK-IN BASKET OPTIONS
TONS OF EXTERIOR AND INTERIOR STORAGE OPTIONS



ASK ABOUT UPGRADING TO THE WORKSTATION ON WHEELS OPTION

WE SPEAK BUCKET TRUCK
DUR-A-LIFT.COM/GUIDE

BROWSE ALL MODEL OPTIONS ONLINE!



DVS-29



**OPTIONAL
WORK STATION
ON WHEELS**
TAKE YOUR OFFICE
ON THE ROAD WITH YOU!



Features dual fold down work tables, movable bench seat, 110V outlet, 2400 to 3600 watt inverter, lights, and Coleman climate control with heat and A/C.



STANDARD

Adjustable wear blocks on main boom; 110V outlet basket; environmentally sealed toggle switches; greaseless bearings; 370° non-continuous rotation; electric over hydraulic controls; upper/lower controls with lower override; maximum operating pressure of 2,100 PSI; 5"x7" rectangular steel main boom; 4"x6" rectangular steel extension boom

OPTIONAL

Hydraulic basket leveling with trim switch at basket; end-hung basket; walk-in basket; full function DC backup; lower remote controls; lower hydraulic basket stow/dump; lower start/stop; electric joystick; torsion bar; tail shelf; basket cover; tool tray; basket heater; fold down seat; splicers basket; battery power; fan belt clutch pump power; all enclosed body storage; work-station on wheels



REACH DIAGRAM

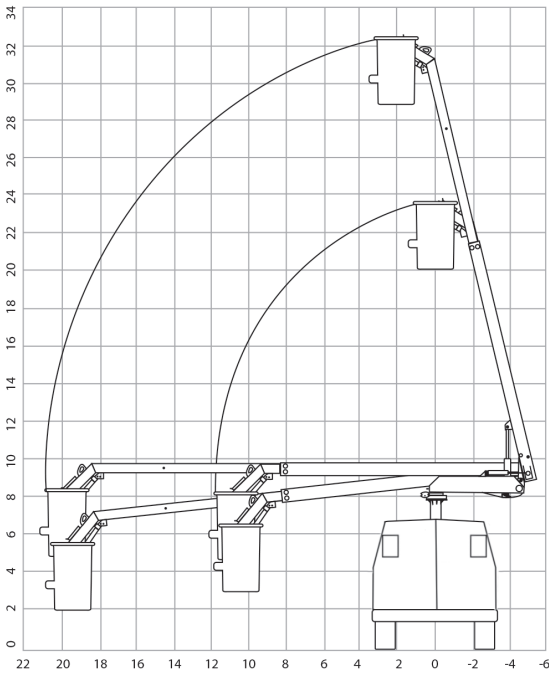

CHASSIS REQUIREMENT, MIN.: 10,000 GVWR
FRONT AXLE REQUIREMENT, MIN.: 3,900 POUNDS



READ MORE



BUILT FOR YOU - ASK ABOUT ALL AVAILABLE FEATURES AND OPTIONS.



DUR-A-LIFT, INC., 2002 KINGBIRD AVENUE, PO BOX 31, GEORGE, IOWA 51237
1-877-438-7254 | SALES@DUR-A-LIFT.COM | DUR-A-LIFT.COM